



*Tomorrow's Telemetry Today!*

DA-TEL RESEARCH COMPANY, INC. • 932 N. PARK AVENUE • P. O. BOX 1206  
 MONTROSE, COLORADO 81402 • PHONE (970) 249-6129 • FAX (970) 249-8919  
 www.da-telresearch.com • EMAIL: info@da-telresearch.com

## G-9794 DUAL ISOLATION RELAY INSTRUCTION INFORMATION

### GENERAL DESCRIPTION

The Dual Contact Multiplier, model G-9794, is a two KYZ input, two outputs per input pulse, contact multiplier. The unit is powered from 115/230/277Vac and has a bi-colored LED indicator per input to show contact activity. The G-9794 is designed with the kWh and kVar installation in mind, with one input for each. The inputs may be driven from the same KYZ pulse and form a one input, 4 output multiplier. The unit comes either mounted in a NEMA-rated enclosure or panel-board mounted with a clear cover.

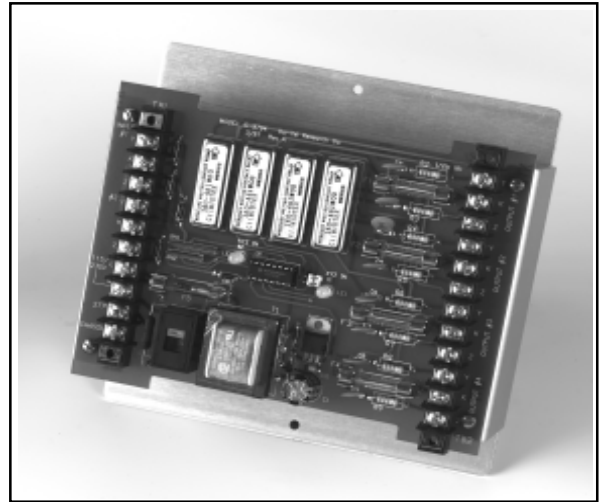

### INSTALLATION

#### Power Connections:

For 115/230Vac installations the line is connected to terminal 7 of TB1 and is labeled "L". S1 must be placed in the ap-

propriate position 115Vac or 230Vac for the system voltage. The neutral is then connected to terminal 8 of TB1 and is labeled "N." For 277Vac system voltages, the line side of the power is moved to terminal 9 of TB1 and is labeled "277V".

S1 must be on the 230Vac setting for proper operation. The chassis connection at terminal 10 of TB1 labeled "CHASSIS" is for the contact in protection circuitry and must be taken to a good ground. The 1/8 Amp fuse, F5, is the power input protection fuse.

*Simplified layout of the G-9794*

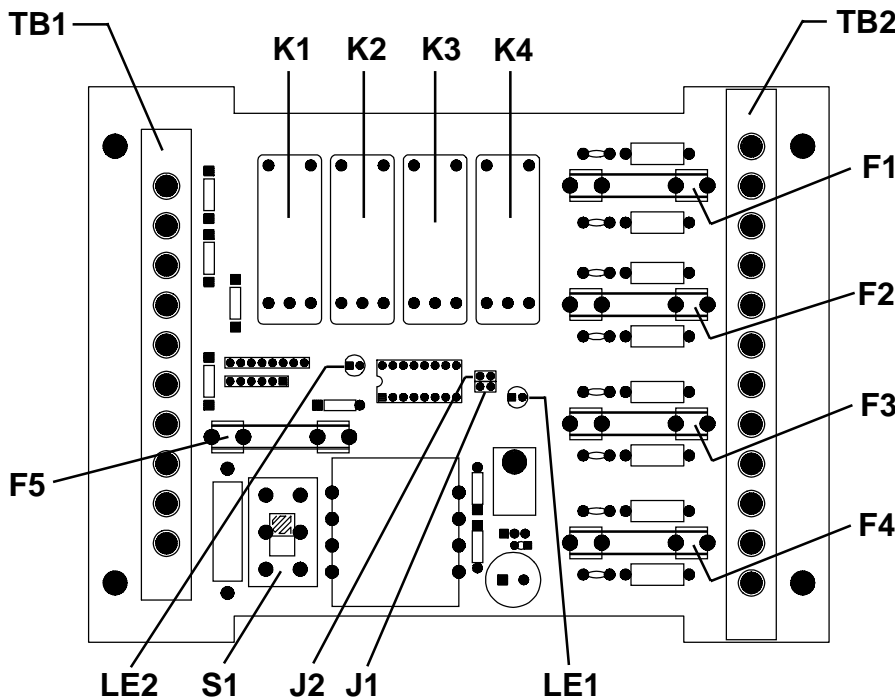

#### Contact Input Connections:

The K-lead of the KYZ contact input is powered by the internal supply of the G-9794 and has a +15Vdc level. If the contact initiator device is polarity sensitive, pay particular attention to this polarity. If the contact initiator is a Form-C device having both a "Y" and a "Z" leg, connect them in the proper position for each input as shown in Table 1. For Form-C inputs, J1 and J2 should be open. If the input devices are only Form-A, the positive side will connect to the K-lead and the remaining side to the Y inputs. J1 and J2 must then be installed. Note that J1 is for Input #1 and J2 is for Input #2. This clearly indicates that each input is separate and that one could be a Form-A input and the other a Form-C input. Once the connections have been made activity on the inputs can be seen by LED activity, LE1 for Input #1 and LE2 for Input #2.

**Contact Output Connections:**

The output contacts for each input are protected by way of a 1A fuse in the K-lead of each relay. The drive for the devices is shown in Figure 1 with the proper connections made according to Table 1. Note that the contacts are rated

**FIGURE 1**

for 2 Amps; however, the 1 Amp fuse gives plenty of safety margin for voltage levels up to 120Vac. For 220Vac systems, the fuse should be smaller to prevent welding of the relay contacts. Limit the power well below 100 watts when sizing the fuses and use fast-blow fuses.

**TABLE 1**

INPUT	K	Y	Z	LED#	OUTPUT	K	Y	Z	FUSE
#1	TB1-2	TB1-1	TB1-3	LE1	#1	TB2-2	TB2-1	TB2-3	F1
					#2	TB2-5	TB2-4	TB2-6	F2
#2	TB1-5	TB1-4	TB1-6	LE2	#3	TB2-8	TB2-7	TB2-9	F3
					#4	TB2-11	TB2-10	TB2-12	F4

**THEORY OF OPERATION**

Form-C inputs into the Dual Contact Multiplier drive the relays in opposing directions when either contact is closed. When K-Y is closed, the inverter drives the top of K1 and K2 low and since Z is floating, its inverter drives the bottom of the relay high. This causes the relay contact to close the K-Y side of the outputs of K1 and K2. When the K-Z position closes, the polarities of the relays invert causing the relays to toggle and the respective K-Z output contacts to close. In Form-A mode (J1 and J2 installed), when K-Y is open, the top of the relays is high and the inverter through J1 drives the bottom of the relays low. When the K-Y position is closed, the opposite occurs and the relay toggles.

**SPECIFICATIONS**

**WEIGHT:** 18 oz. without NEMA-rated enclosure or cover.

**SIZE:** 7"L x 6.75"W x3"H (w/o cover)

**PANEL MOUNTING HOLES:**  
2 Holes on vertical center spaced

**TESTING AND CALIBRATION**

To properly test the Dual Contact Multiplier, model G-9794, apply each system voltage and measure pin 1 of VR1. This voltage should be greater than 18Vdc but less than 22Vdc.

With a system voltage of 115Vac connect a Form-C contact across each input. Check to see that LE1 and LE2 are changing from green to red at the contact rate. Check the output of each relay with continuity for both sides. A slow rate will facilitate this method. For Form-C inputs ensure that J1 and J2 are open. Use a N.O. contact across the K-Y inputs, install J1 and J2 and ensure that the LEDs are changing and the relays moving.

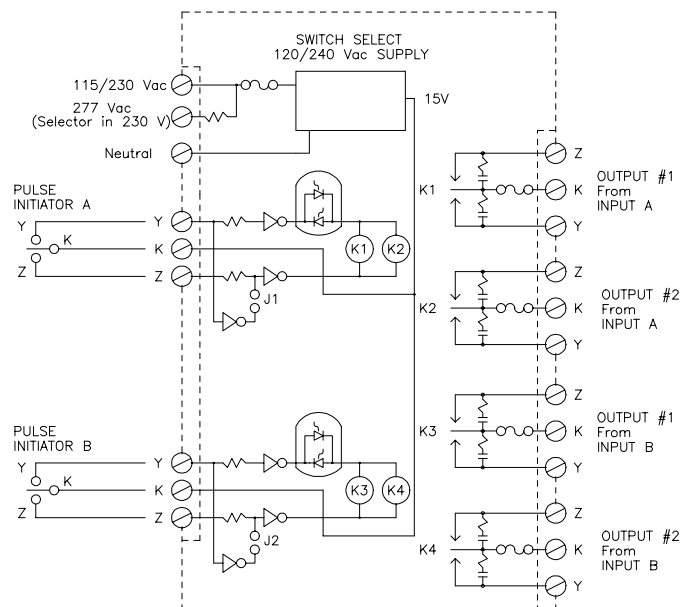

**Simplified Schematic Diagram of the G-9794**